

Container Docking Stations – System Variants

A) four-legged stand with continuous wheel guide

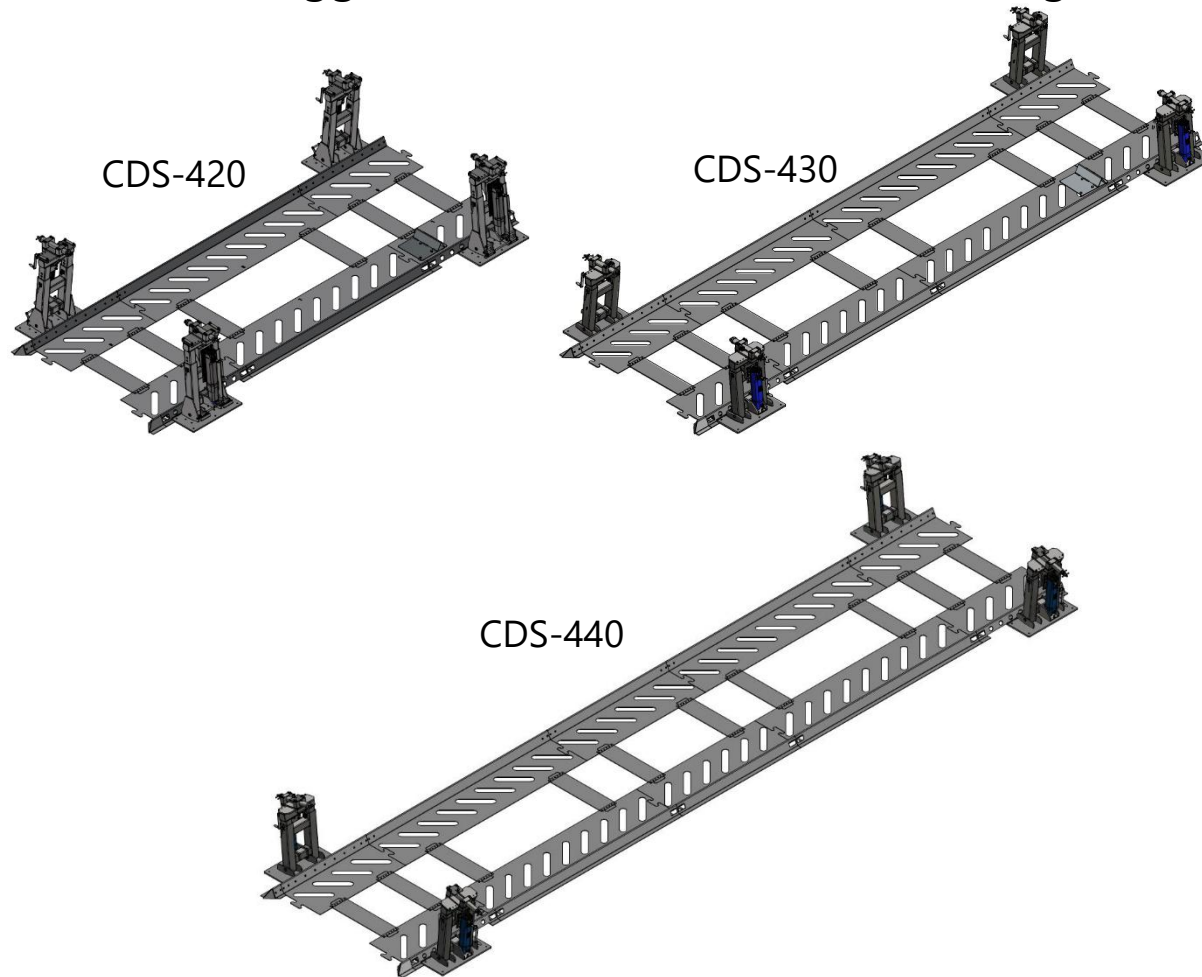

B) flexible with positionable supports

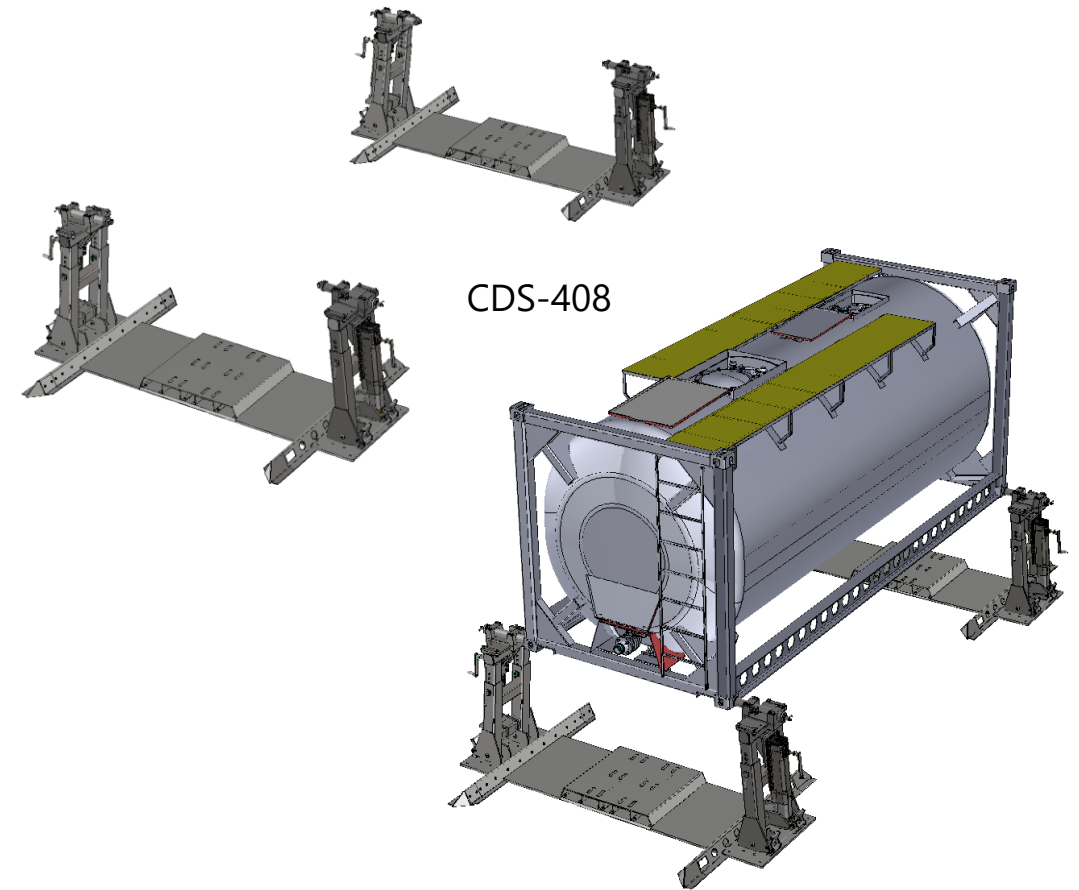

Container Docking Stations – System Variants

Series-400 Suitable for containers with ISO corner castings							
Product	typical Sizes		Max. load capacity	Legs	Stacking Height**	Examples	Special features
CDS-420	20'	also with longitudinal overhang	34t	fix	1'100 - 1'450 mm	All Box / Silo / Tank- Container or Swaptainer with ISO corner castings	Coupling and securing via the side hole of the ISO corner casting. The height is manually adjustable (even under load).
CDS-430	30'		34t	fix	1'100 - 1'450 mm		
CDS-440	40' & 45'*		34t	fix	1'100 - 1'450 mm		
CDS-408	10' - 45'*	also with longitudinal overhang	34t	mobil	1'100 - 1'450 mm		
* Applies to 45' containers or 45' swap bodies fitted with ISO corner castings in the 40' position (with side hole)							
Serie-300 Suitable for Swap Bodies with "Grappler-Plates"							
Product	typical Sizes		Max. load capacity	Legs	Stacking Height**	Examples	Special features
CDS-310	C745	Legs at position of the Grappler Plates	20t	fix	1'000 - 1'400 mm	UIC certified Swap Bodies with Grappler Plates	This version is under development
	C782						
** The stacking height is measured at the base plates of the corner castings of the container.							