

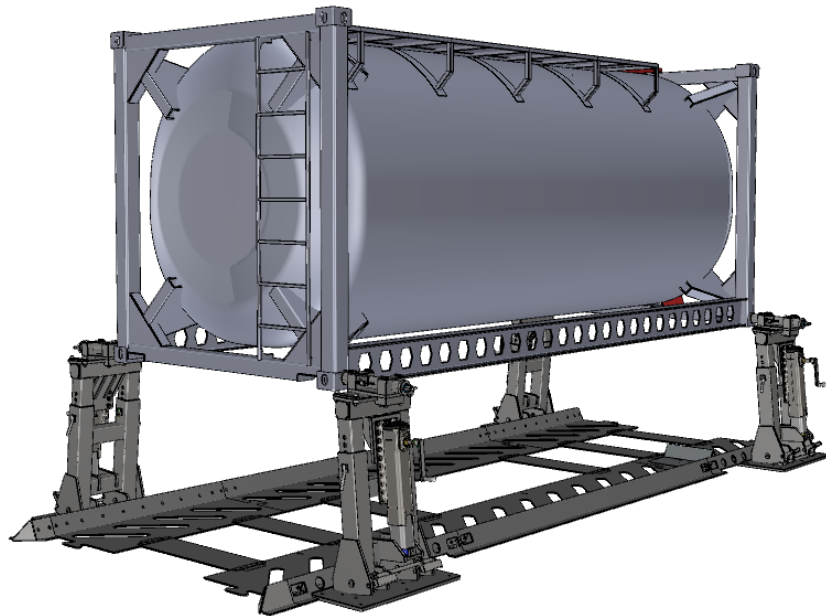

The Container Docking Station

Discover the advantages in container handling



Introducing the Container Docking Station (CDS)

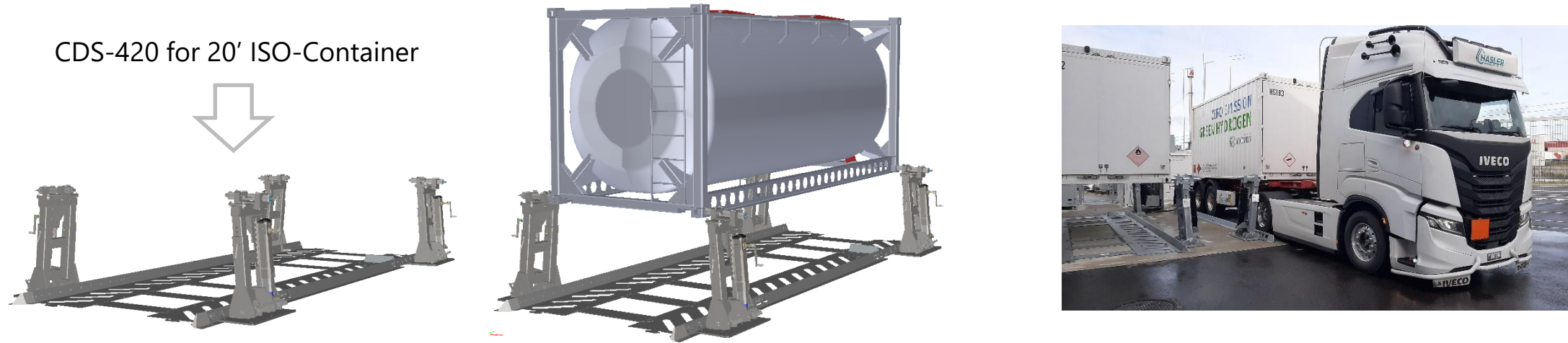

- CDS-420/440 for parking and pickup of 20-40 ft containers with ISO corner castings
- Independent handling by the truck driver, no need for container lifting by a crane
- Successful track record in a nationwide Swiss hydrogen logistics network and other projects
- DEKRA-certified for a payload up to 34 tons, installation anchored in the ground
- Designed according to DIN EN 1998-1/NA regarding earthquake safety (Eurocode 8)

Parking/picking up containers in 5 minutes

It works as follows:

- Truck entry to park/pick up the container
- Container transfer with truck air suspension system
- Securing the container with twist lock couplings through corner fittings
- Truck exit (with or without container)



Parking (and pick-up)
in 5 minutes



The advantages: flexibility and cost cutting potential

These are the advantages:

- Flexible handling, e.g. with container swaps (next page) or freeing the truck chassis
- Cost cutting potential, e.g. compared with a fixed tank storage
- Easy Docking Station maintenance
- Possibility to combine with train or barge transport -> reducing CO2 emissions



Swift container swaps and other advantages

Swapping mostly means swapping a full container against an empty one (or vice versa).

The truck driver can do the swap at a moment fitting in his(her) working schedule.

Thus, the Docking Station offers you new opportunities to plan container logistics.

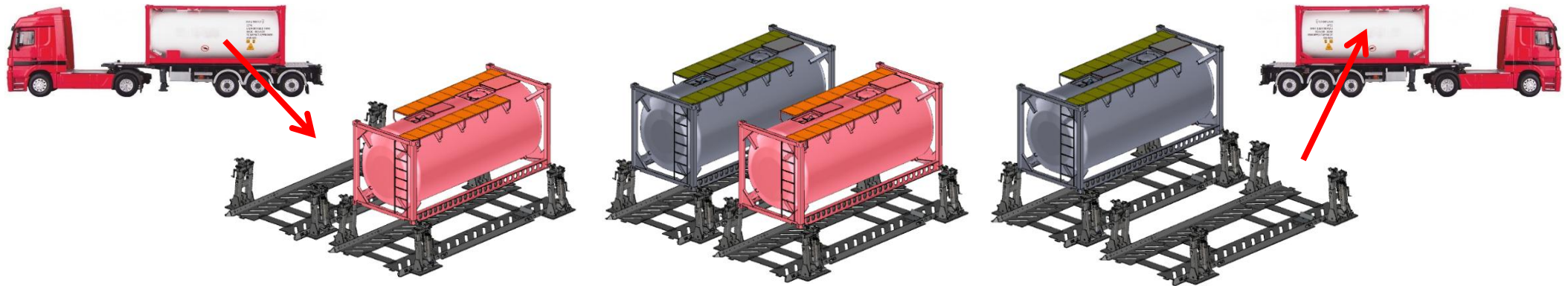

The swap only takes 15 minutes [Video](#).

References



Available for more information

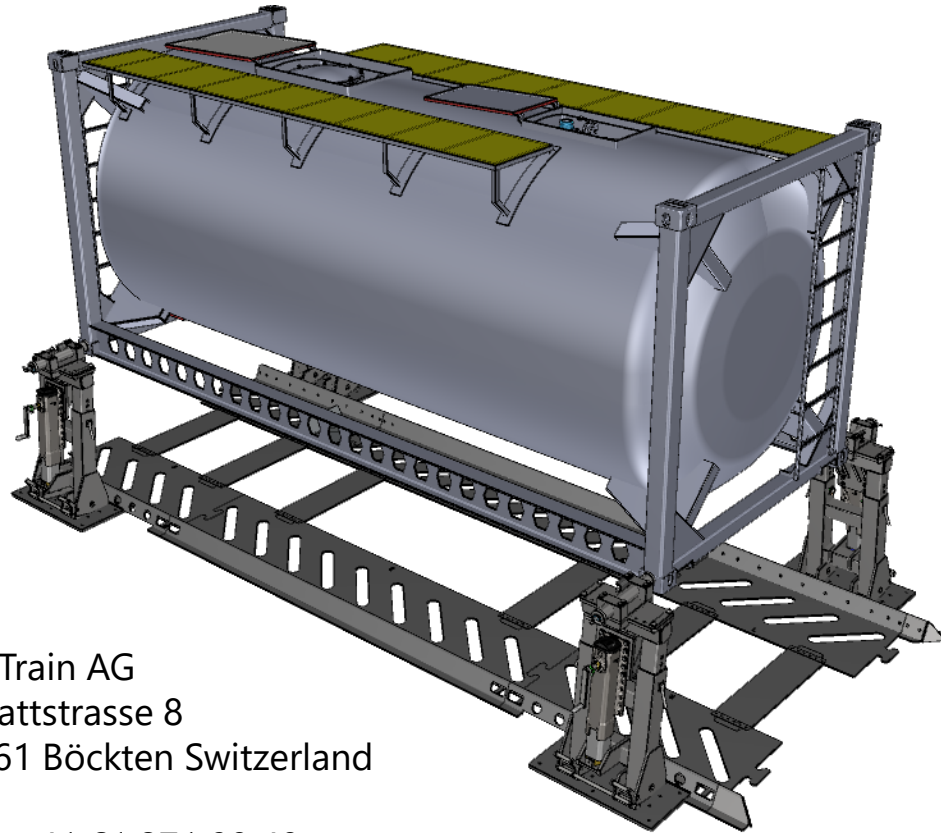

InnovaTrain AG
Rohrmattstrasse 8
CH-4461 Böckten Switzerland

Phone +41 61 271 90 40
www.innovatrain.ch
info@innovatrain.ch

Thank you for your attention

We will gladly answer any questions on the use of the Container Docking Station.

